

Virtual Physics

Equation-Based Modeling

TUM, October 21, 2014

Modeling in Modelica – Graphical Modeling

```
model SimpleCircuit "A simple RC circuit"  
  import SI = Modelica.SIunits;  
  parameter SI.Capacitance C = 0.001 "Capacity";  
  parameter SI.Resistance = 100 "Resistance";  
  parameter SI.Voltage V0 = 10 "Source Voltage";  
  SI.Current i "Current" ; SI.Voltage uC  
  "Capacitor Voltage";  
initial equation  
  uC = 0;  
equations  
  V0-uC = R*i;  
  der(uC)*C = i;  
end SimpleCircuit;
```

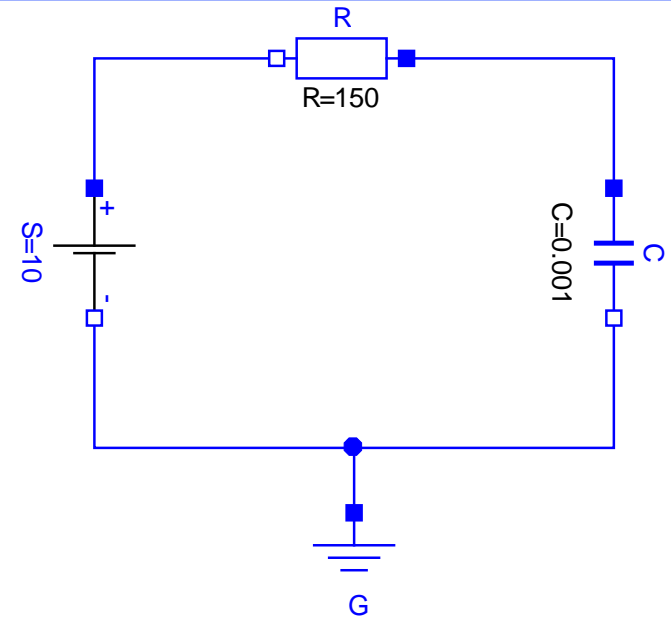

Dr. Dirk Zimmer

German Aerospace Center (DLR), Robotics and Mechatronics Centre

In this lecture, the language
Modelica is officially introduced.

- The graphical modeling layers in Dymola
- Annotations
- Parameter GUI
- Initialization via GUI
- Modelica Blocks
- Inputs / Outputs
- Blocks and Functions

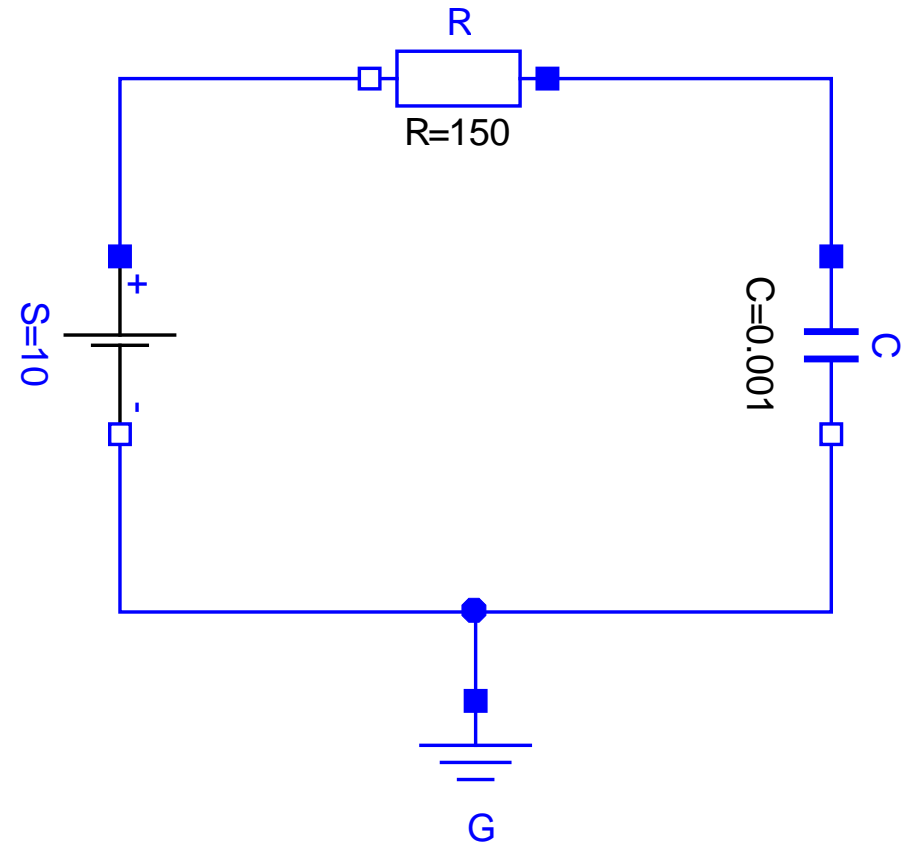

So far, we have only looked at the textual side of modeling.

- Using a modern modeling environment like Dymola, most modeling is performed graphically.
- Textual modeling is only done for the lower level tasks.

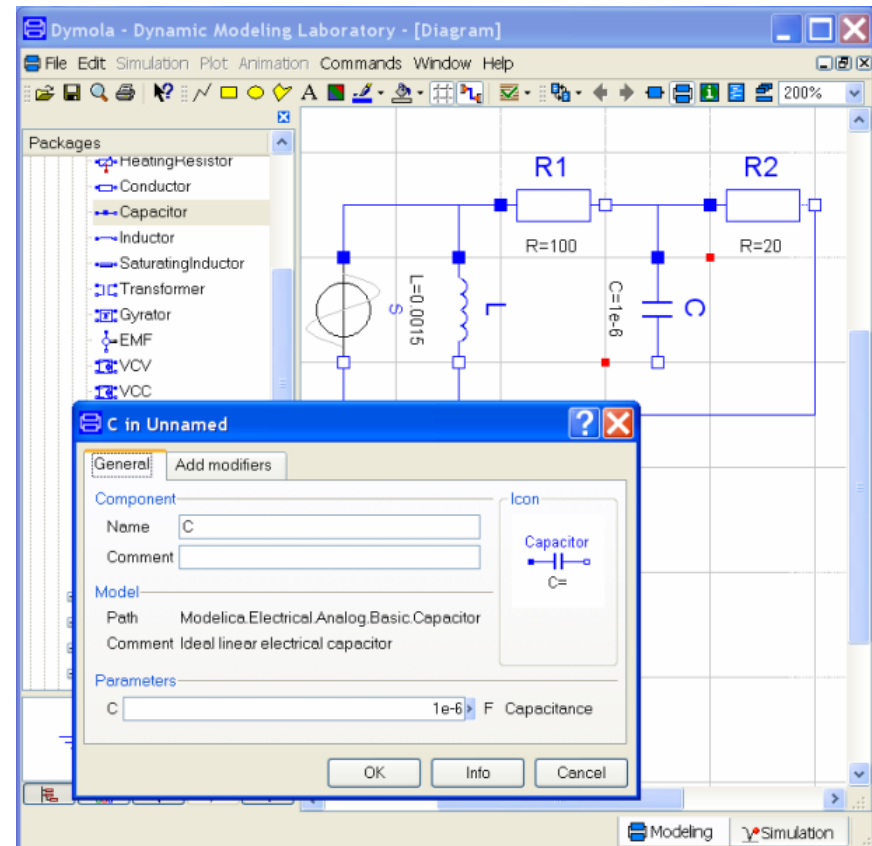

To this end, Dymola offers three distinct modeling layers.

- The inner textual representation (1)
- The inner graphical representation (2)
- The outer graphical representation (3)

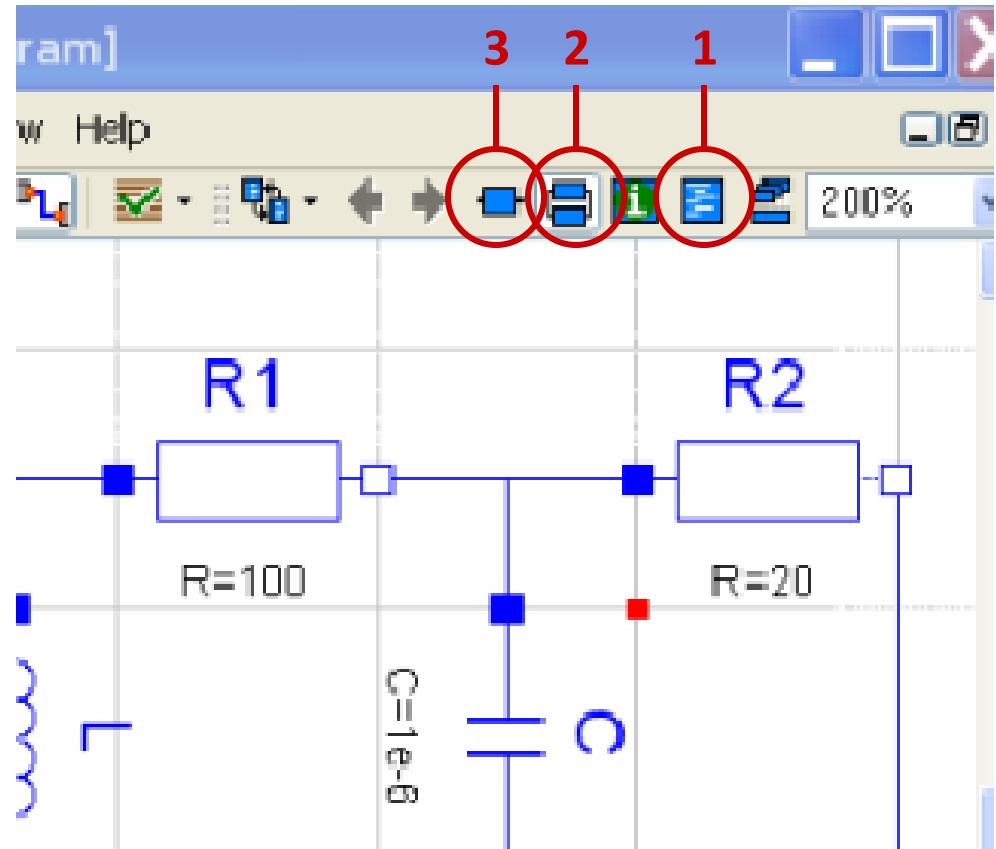

Let us model an RC-Filter.

- We start with the inner graphical representation.
- Here we model the actual sub-circuit

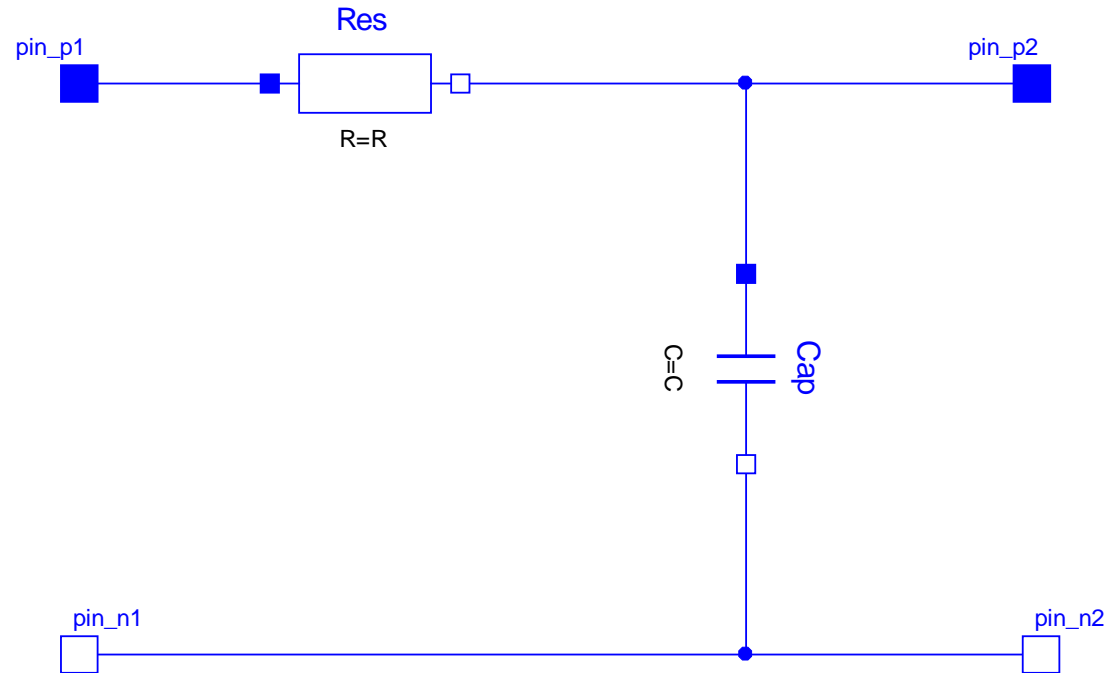

Let us model an RC-Filter.

- On the textual layer, we provide two parameters for the resistor and the capacitor

```
model RCFilter
  import SI = Modelica.SIunits;
  parameter SI.Resistance R = 100;
  parameter SI.Capacitance C = 1e-3;

  Modelica...Resistor Res(R=R);
  Modelica...Capacitor Cap(C=C);
  Modelica...NegativePin pin_n1;
  Modelica...NegativePin pin_n2;
  Modelica...PositivePin pin_p1;
  Modelica...PositivePin pin_p2;
equation
  connect(pin_p1, Res.p);
  connect(Res.n, pin_p2);
  connect(Cap.p, Res.n);
  connect(Cap.n, pin_n2);
  connect(pin_n1, pin_n2);
end RCFilter;
```

Let us model an RC-Filter.

- The outer graphical representation already contains the connectors
- Now we design a suitable symbol for our model.
- Now it is ready to be used.

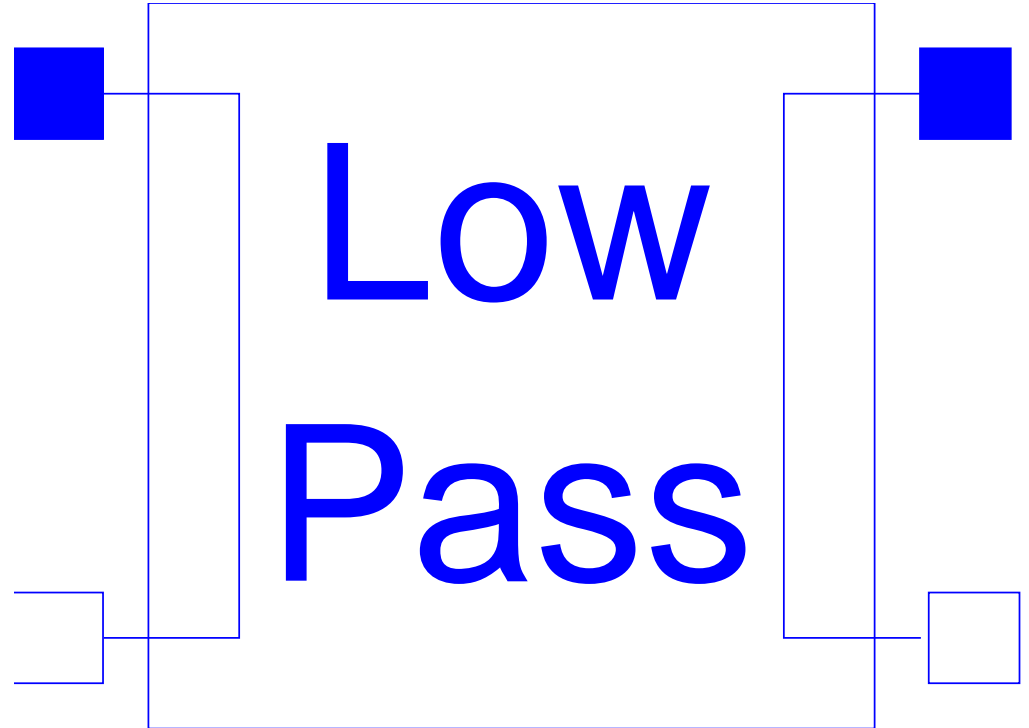

Let us model an RC-Filter.

- Here is an application of our RC-Filter component.
- The parameters can be set by clicking on the component.

$$C = 0.01$$

$$R = 5$$

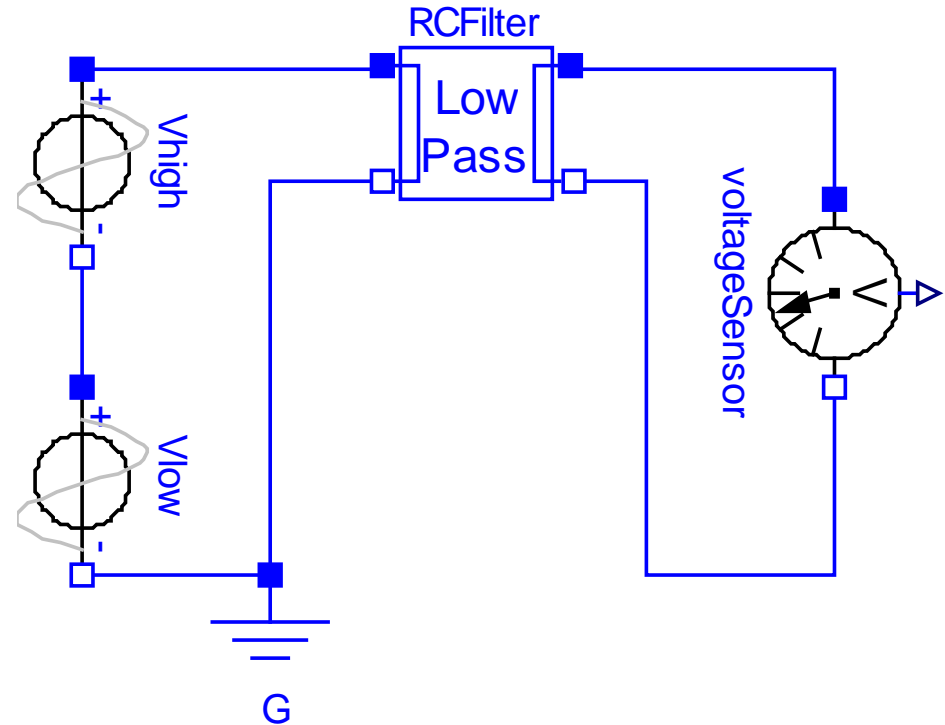

Simulation Result

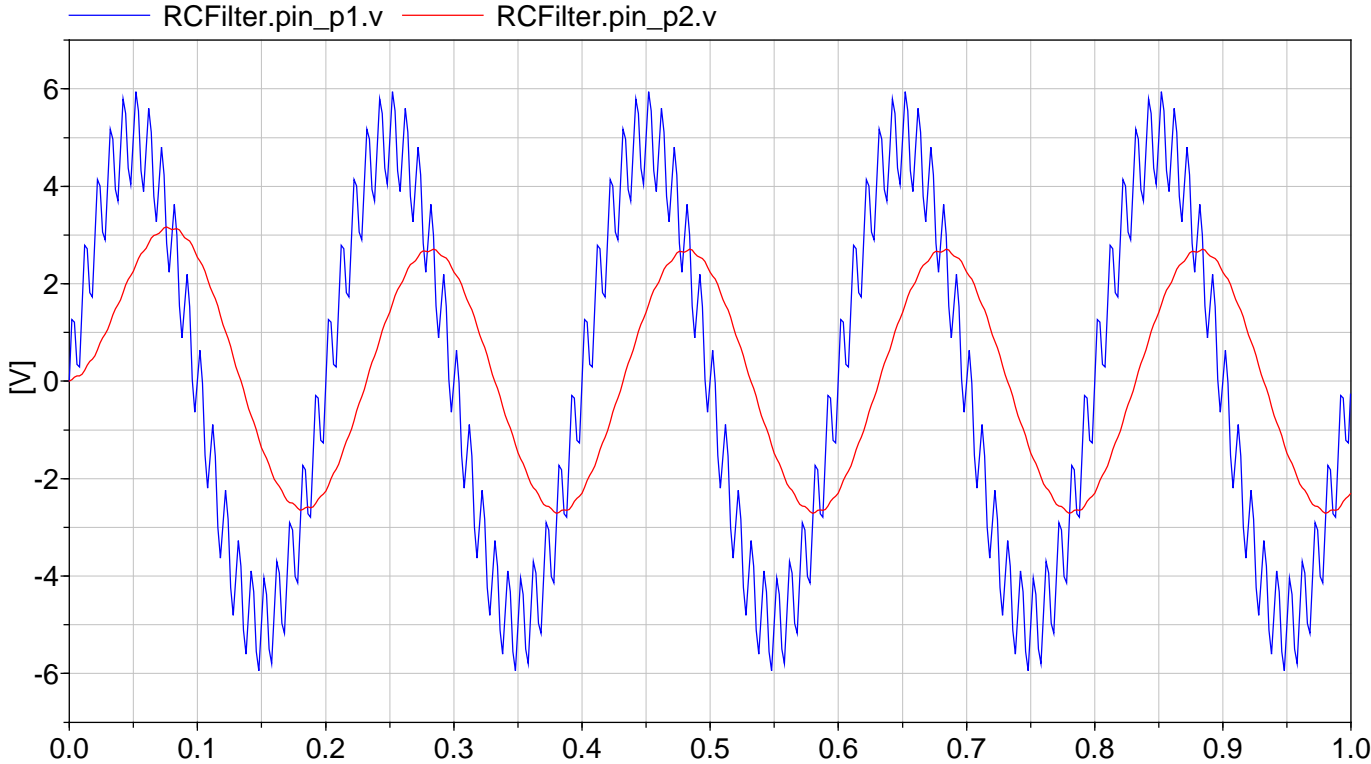

```
model RCFilter
  import SI = Modelica.SIunits;
  parameter SI.Resistance R = 100;
  parameter SI.Capacitance C = 1e-3;

  Modelica...Resistor Res(R=R) a;
  Modelica...Capacitor Cap(C=C) a;
  Modelica...NegativePin pin_n1 a;
  Modelica...NegativePin pin_n2 a;
  Modelica...PositivePin pin_p1 a;
  Modelica...PositivePin pin_p2 a;
equation
  connect(pin_p1, Res.p) a;
  connect(Res.n, pin_p2) a;
  connect(Cap.p, Res.n) a;
  connect(Cap.n, pin_n2) a;
  connect(pin_n1, pin_n2) a;
end RCFilter;
```

- How is the graphical information stored within the model.
- Modelica uses annotations for this purpose.
- Dymola typically hides annotations and represents them by the symbol: **a**
- The visibility of annotations can be enabled in the Dymola Editor.

```
annotation( Icon( graphics={  
  Rectangle(  
    extent={{-80,80},{80,-80}},  
    lineColor={0,0,255},  
    fillColor={255,255,255},  
    fillPattern=FillPattern.Solid),  
  Line(  
    points={{-90,60},{-60,60},  
            {-60,-60},{-90,-60}},  
    color={0,0,255},  
    smooth=Smooth.None),  
  Line( points={{90,60},{60,60},  
               {60,-60},{90,-60}},  
    color={0,0,255},  
    smooth=Smooth.None),  
  Text( extent={{-60,60},{60,2}},  
        lineColor={0,0,255},  
        textString="Low" ),  
  ...
```

- How is the graphical information stored within the model.
- Modelica uses annotations for this purpose.
- Dymola typically hides annotations and represents them by the symbol: **a**
- The visibility of annotations can be enabled in the Dymola Editor.

```
annotation(  
Documentation(info=  
    "<html>  
    <p><h4>RC-Lowpass</h4></p>  
    <p>This is a basic model of an  
    RC-Lowpass filter.</p>  
    </html>")  
);
```

```
parameter SI.Resistance  
R = 1 annotation(  
    Dialog(  
        group="RCSpecification"  
    )  
);
```

- Annotations are also used to store the HTML-documentation of the model
- Also the the look of the Parameter GUI can be determined by annotations.

Following classifications of aspects seems appropriate for Modelica

Physical modeling: The modeling of the physical processes that are based on differential-algebraic equations (DAEs).

System hints: The supply of hints or information for the simulation-system.

3D Visualization: Description of corresponding 3D-entities that enable a visualization of the models.

GUI-Representation: Description of an icono-graphic representation for the graphical user-interface (GUI) of the modeling environment.

Documentation: Additional documentation that addresses to potential users or developers.

- Modelica.Thermal.
FluidHeatFlow.Examples.
PunpAndValve

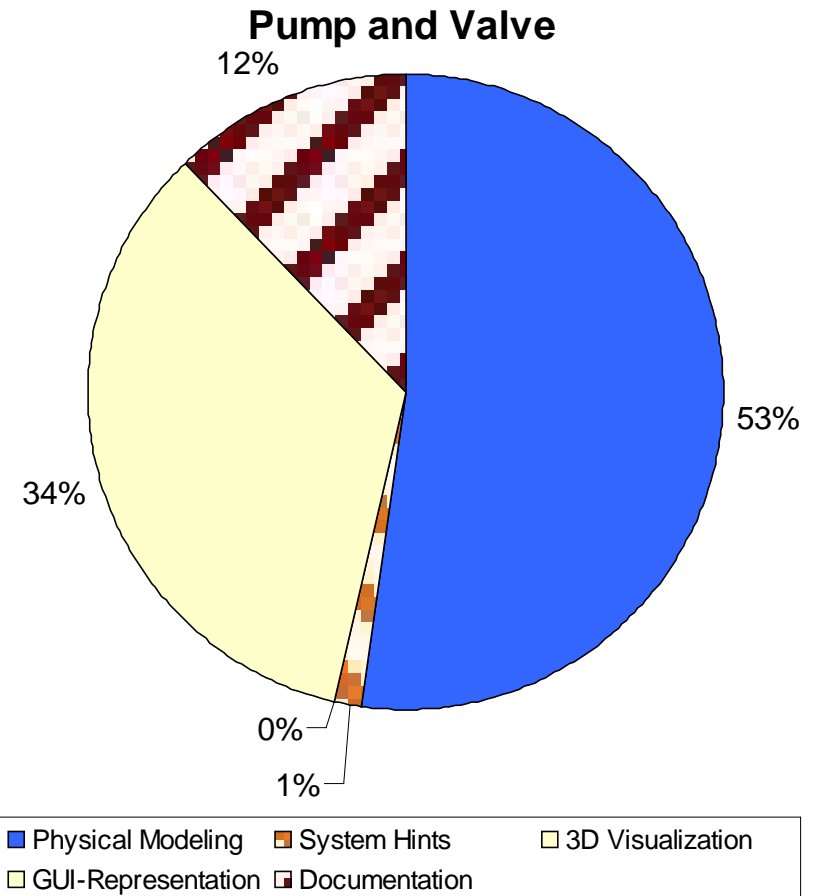
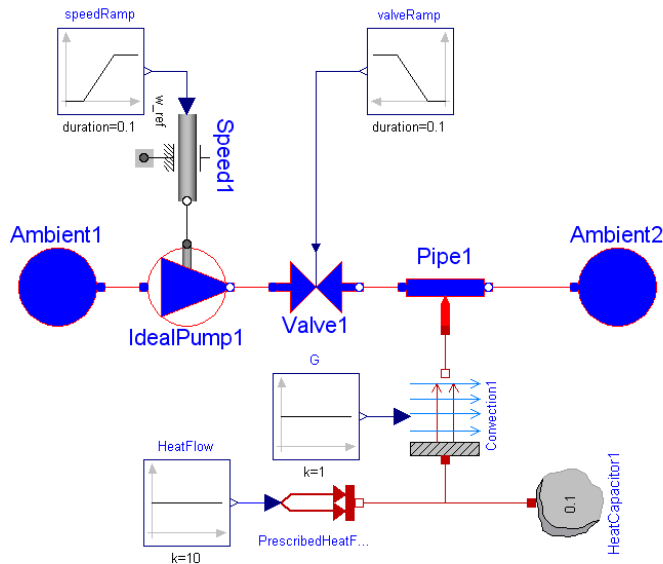

- Modelica.Electrical.
Analog.Semiconductors.
PMOS

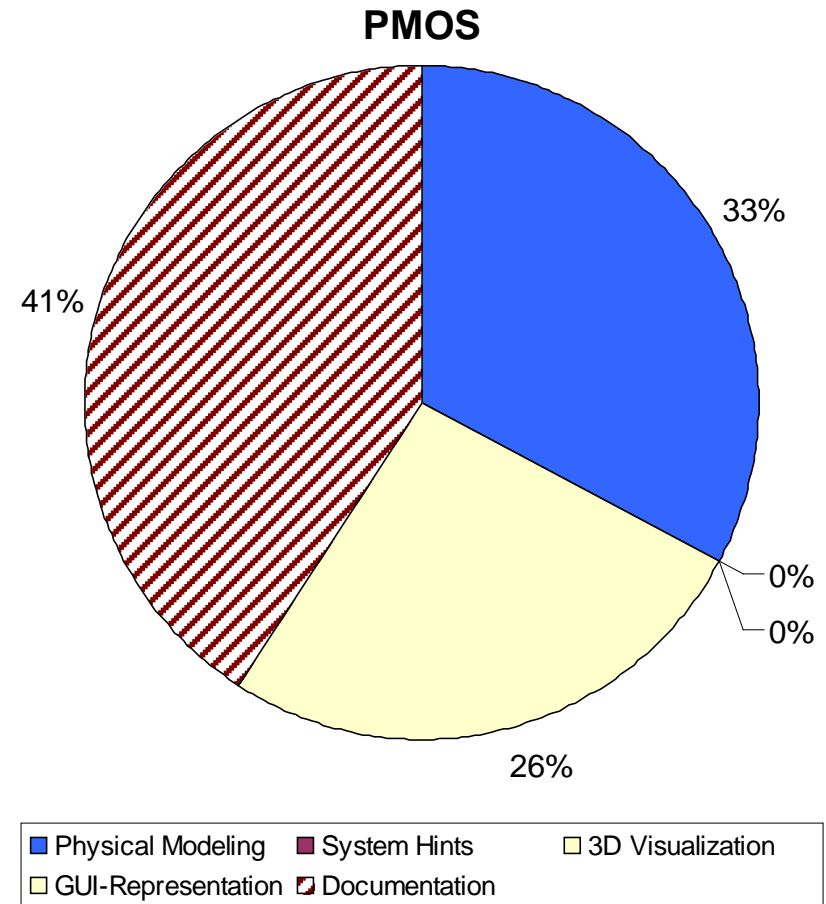
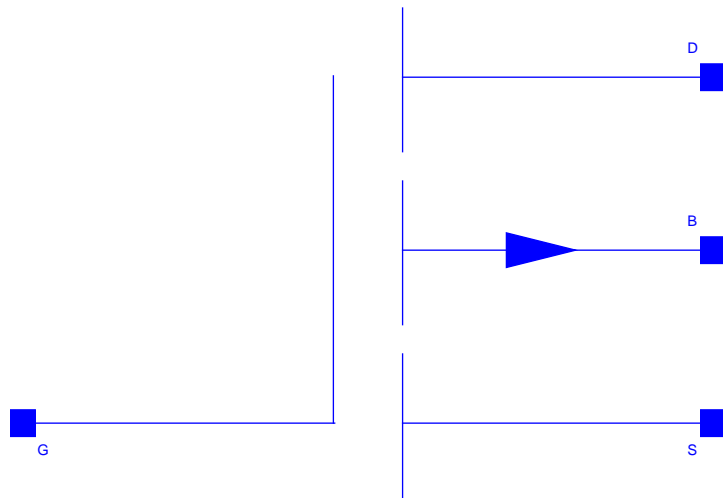

- Modelica.Mechanics.
MultiBody.Parts.
FixedTranslation

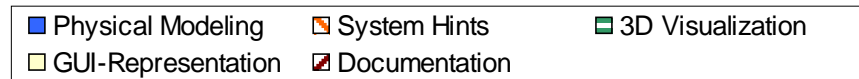
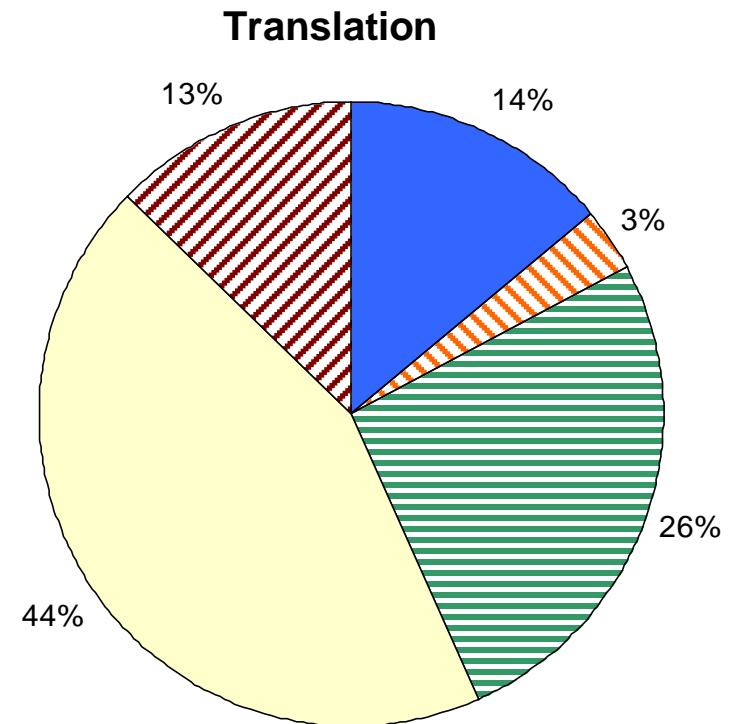
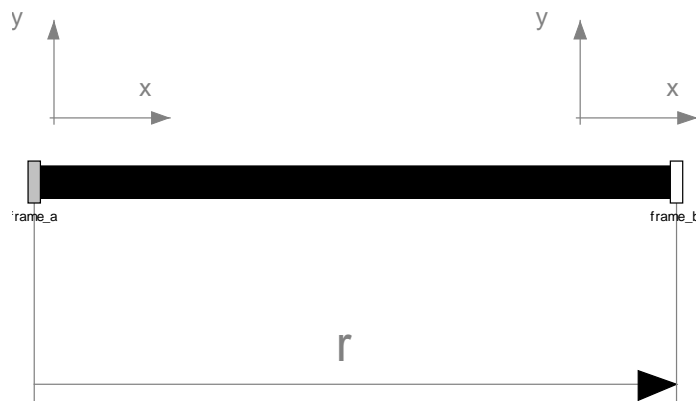



```
model RCFilter
  import SI = Modelica.SIunits;
  parameter SI.Resistance R = 100;
  parameter SI.Capacitance C = 1e-3;
  parameter Boolean initialize
    = false;
  parameter Real vC0;
  Modelica...Resistor Res(R=R);
  Modelica...Capacitor Cap(C=C);
  Modelica...NegativePin pin_n1;
  ...
  initial equation
  if initialize then
    Cap.v = vC0;
  end if;

  equation
    connect(pin_p1, Res.p);
    connect(Res.n, pin_p2);
    ...
end RCFilter;
```

The set of initial conditions depends on the circuit structure. Hence, they must be stated globally for each new system.

To enable a convenient formulation of the initial conditions, parameters are often offered.

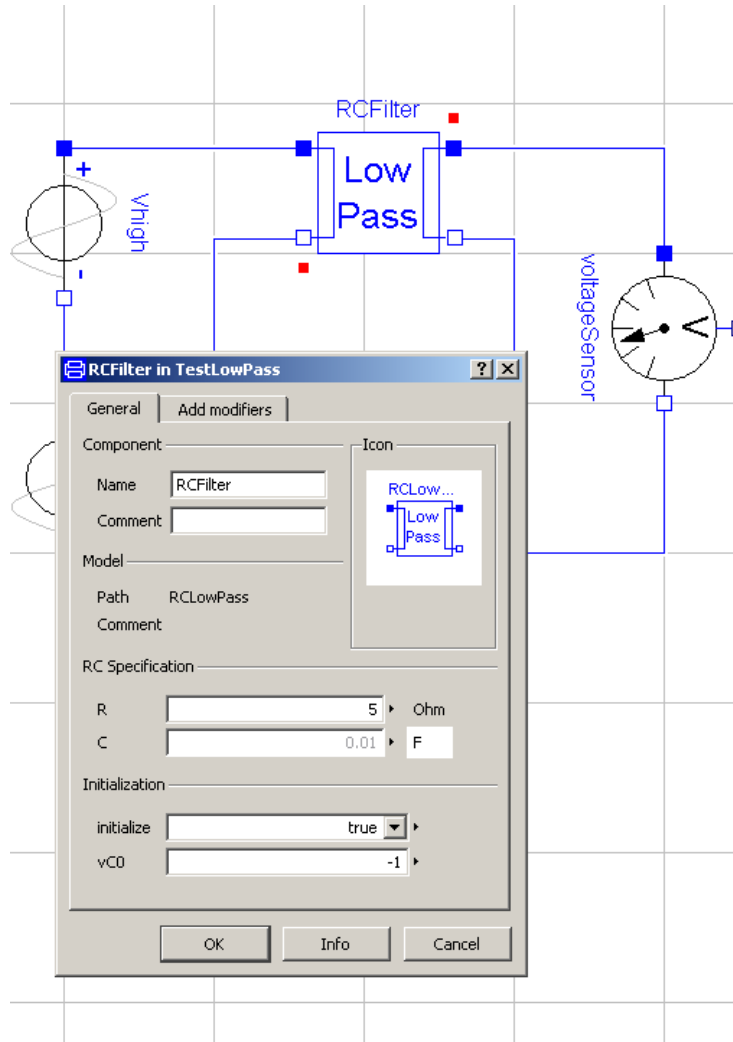
We use our RC-Circuit as an example.



- Within an electric circuit, the modeler can select the components he wants to initialize.
- Not all combinations are valid!
- This is a topic that will be discussed intensively in future lectures.

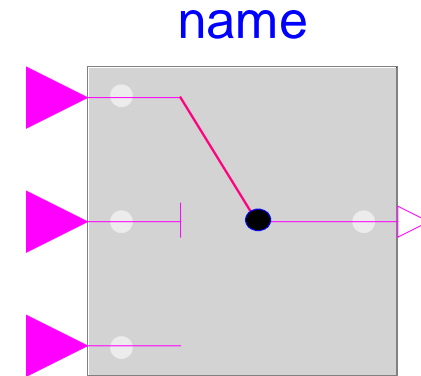
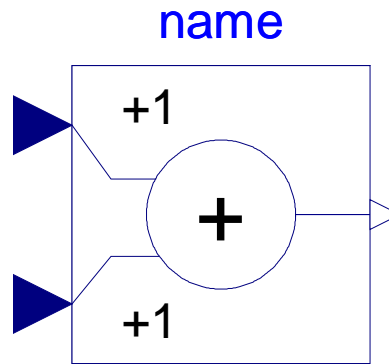
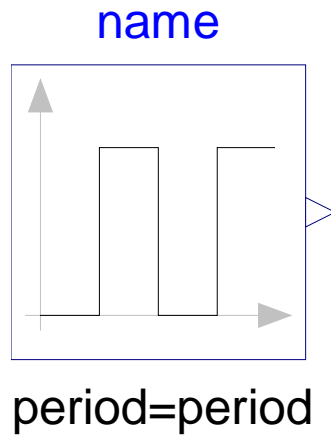

- Not all modeling work represents physical processes.
- Often we want to model signals. This can include simple algebraic computations or elaborate control loops.
- Modelica offers the Modelica.Blocks Library for this purpose.

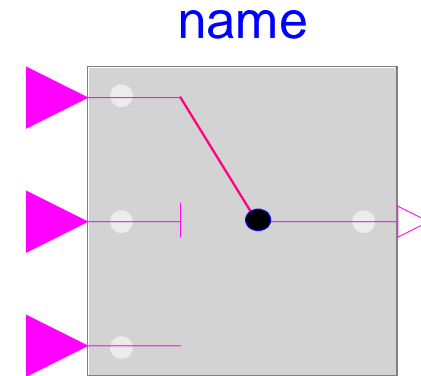
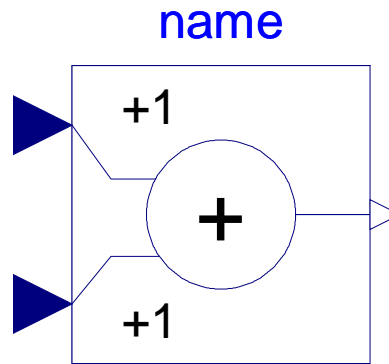
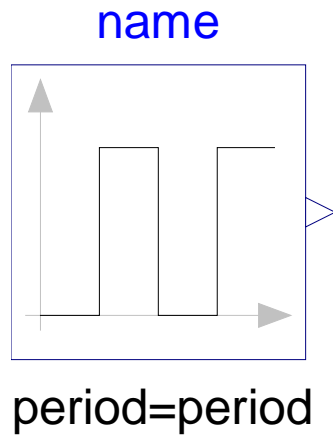

- Modelica Blocks features a variety of models.
- There are various signal sources and algebraic and logic elements
- Also a number of control elements is ready to be used.

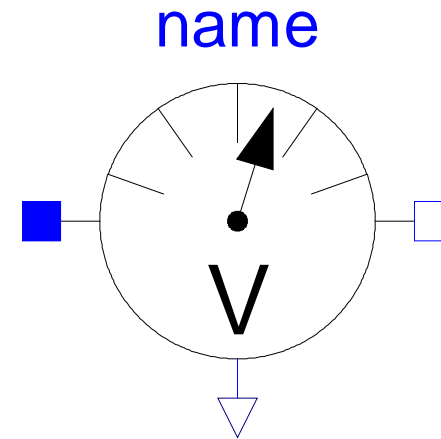
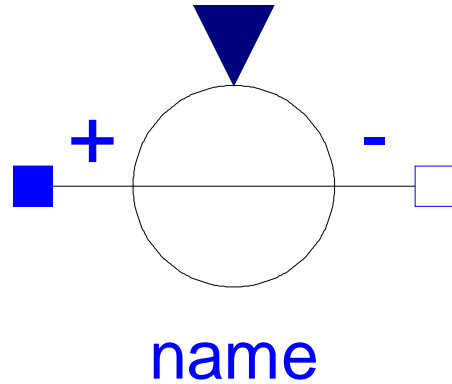

- Blocks can interact with physical models by the means of...
- ...Sensors...
- ... and Sources

Application Example

Here we use Block models..

- ...to describe an rectangular source voltage signal
- ...and to compute the difference voltage between input and output.

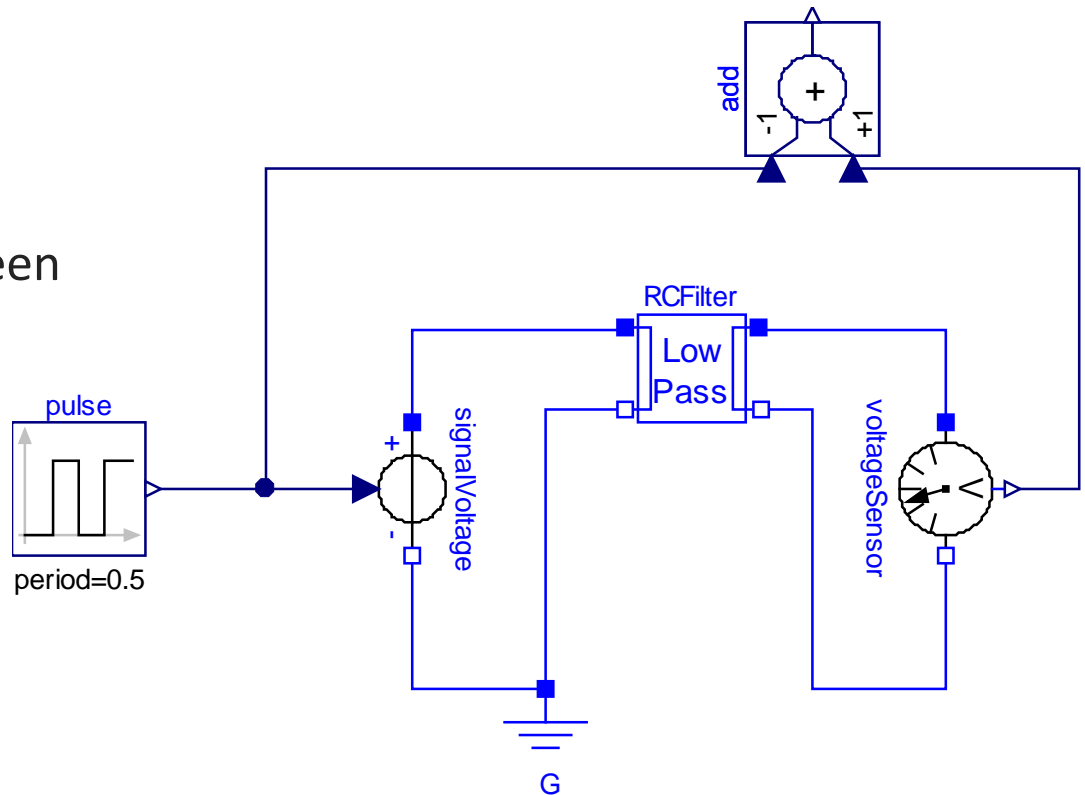

Here we use Block models..

- ...to describe an rectangular source voltage signal
- ...and to compute the difference voltage between input and output.

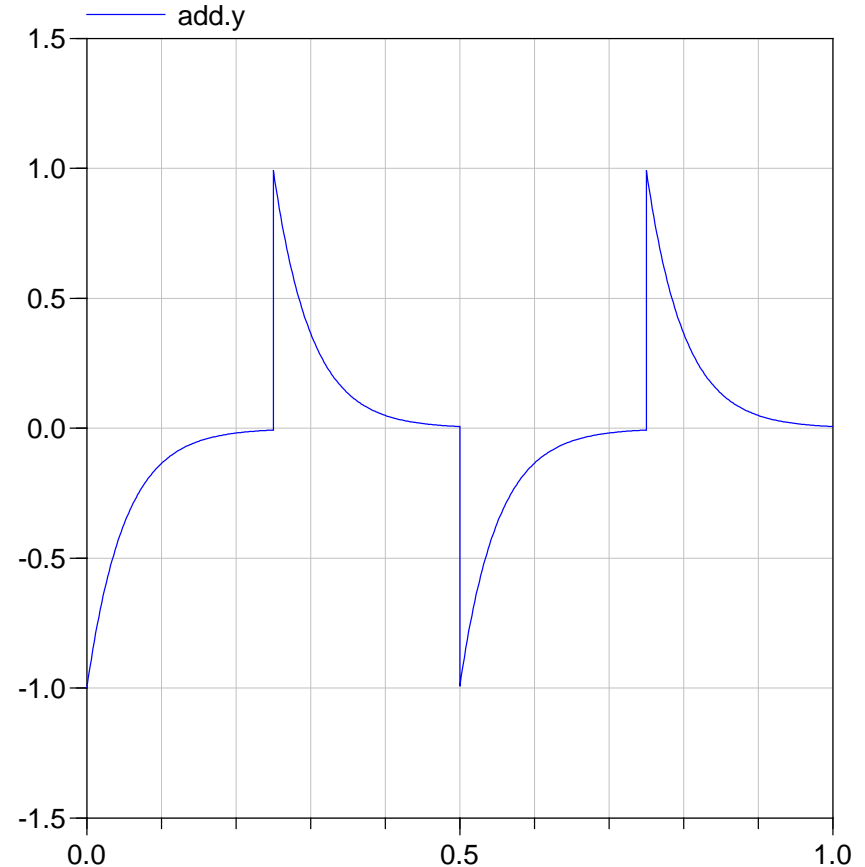

```
block Add
```

```
RealInput u1;  
RealInput u2;  
RealOutput y;
```

```
parameter Real k1=+1;  
parameter Real k2=+1;
```

```
equation
```

```
y = k1*u1 + k2*u2;
```

```
end Add;
```

- Blocks use different connectors.
- There are input connectors and output connectors.
- Any input must be connected to an output.
- An output can be connected to an arbitrary number of matching inputs.
- The input-output relation does NOT impose a computational causality. It might be that the input is computed, given the desired output.

```
block Add
```

```
RealInput u1;  
RealInput u2;  
RealOutput y;
```

```
parameter Real k1=+1;  
parameter Real k2=+1;
```

```
equation
```

```
y = k1*u1 + k2*u2;
```

```
end Add;
```

- A block is simply a model that has only input and output connectors.
- When locally checking a block, all inputs are assumed to be known and all outputs represent unknowns.
- Blocks may define state-variables
So does the integrator block.

```
function fak

    input Integer n;
    output Integer y;

algorithm

    y := 1;

    while n>1 loop

        y := y*n;
        n := n-1;

    end while;

end fak;
```

- A function is similar to a block.
- Functions have an arbitrary number of inputs and outputs.
- The order of declaration does matter since this determines the way the function is called.
- In contrast to blocks, functions cannot define state-variables. Also parameter declarations are not allowed in functions

```
function fak

  input Integer n;
  output Integer y;

algorithm

  y := 1;

  while n>1 loop

    y := y*n;
    n := n-1;

  end while;

end fak;
```

- The computation of the function is typically expressed within an algorithm section.
- Auxiliary variables (non-input/output) must be declared protected.
- The algorithm section simply expresses a sequence of computations as in imperative programming languages. There exist even loop statements.
- Modelica functions must be pure, this means they shall not contain side-effects. (There are exceptions)

```
[...]  
  
z = sin(phi)*g  
z = der(w)  
w = der(phi)  
  
[...]
```

- The function may now be used within the equations section of a model.
- This is not a direct function call, since the simulator will finally determine if and how many times the function will be called.
- This is also the reason why the function must (or should) be free of side-effects.

Let us conclude by a few general remarks

- Most higher-level modeling is performed graphically.
- Annotations are used to store the corr. information.
- Physical modeling is extended by blocks and functions.
- Blocks are often used to design a controller.
- Algorithmic parts are supported by means of functions.

- Next lecture, we are going to examine the compilation of Modelica Models.

Questions?